

Thin Line Fire Damper ▲ 1 5/8" Deep ▲ 1 1/2 Hour ▲ Vertical Mount ▲ Dynamic Rated

STANDARD MATERIALS AND CONSTRUCTION

- FRAME:** 1 5/8" x 5/8" x 22-GA one piece formed galvanized steel channel with mitered corners.
- BLADE:** 22-GA galvanized steel, curtain type.
- CLOSURE SPRINGS:** Heat-treated Type 301 stainless steel constant force coiled negator type.
- FUSIBLE LINK:** UL-Listed 165°F; Replaceable.
- FINISH:** Mill.

OPTIONS

- 212°F Replaceable Fusible Link
- Factory-Supplied Sleeves (20-GA through 10-GA)
- PK1202 Position Indicator Switch
- Tab-Lock Retaining Angles
- Pull Ring

NOTES

1. Nominal deductions will be made to the opening size given.
2. Thin Line Dampers have no frame area outside of the blade track. Sleeves provided by others must be stitch welded to the damper on both faces, with 1/2" minimum long welds on 6" maximum centers, The first and last welds must be no more than 3" apart.

DAMPER SIZES

2000 fpm, 4 in. w.g.	
Vertical (Wall)	
Min Panel	Max Single Panel
4"W x 4"H	24"W x 24"H

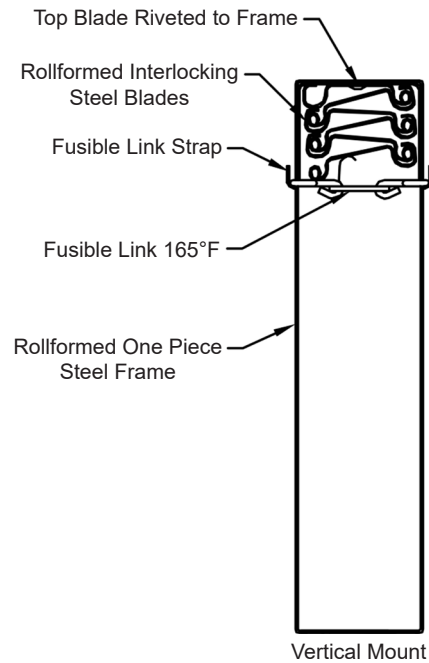

Vertical Mount

UNDERWRITERS LABORATORIES INC.®
 CLASSIFIED DYNAMIC FIRE DAMPERS
 FIRE RESISTANCE RATING 1 1/2 HR

FILE # R4708

This fire damper meets the construction and performance requirements of:

- Underwriters Laboratories Inc. Standard 555
- National Fire Protection Association Standard 80, 90A, 101
- ICC's International Building Code
- California State Fire Marshal Listing #3225-1328:100
- Underwriters Laboratories Inc. Approved for dual direction airflow and dynamic closure conditions.
- Underwriters Laboratories Inc. Classified for use in fire resistive ratings of less than 3 hours.

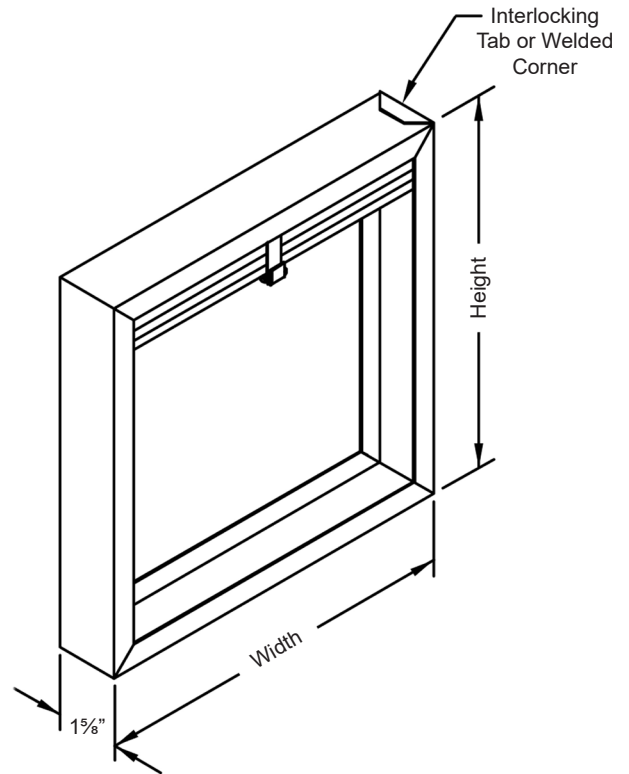

Item #	Qty	Damper Size	Factory Sleeve	165°F	212°F				
				Fusible Link		Union Made			
Arch. / Eng.:			EDR:	ECN:	Job:				
Contractor:									
Project:			Date:	DWN:	DWG:				

PRESSURE DROP DATA

Pressure Drop
(For a 24" x 24" Sample)

Velocity (FPM)	ΔP (in. w.g.)
500	0.03
1000	0.11
1500	0.25
2000	0.44

Tested in accordance with AMCA Standard 500-D, Fig. 5.3

Pressure Drop
(For a 12" x 12" Sample)

Velocity (FPM)	ΔP (in. w.g.)
500	0.05
1000	0.21
1500	0.47
2000	0.84

Tested in accordance with AMCA Standard 500-D, Fig. 5.3